

## Installation Instructions for DOT LED Round & Square

### IMPORTANT INFORMATION

- This product is type IC and can be installed as recessed (access above the installed location is required) or surface mount.
- It is recommended to use the HUB-4P or HUB-8P to power the Dot Lights.
- This product should be used with a 12VAC TEB-60L-12 power supply when it is to be dimmed with a low-voltage electronic dimmer or with a 12VDC TEB-60L-12DC power supply.
- This installation instruction shows typical installation.
- This product is suitable for damp locations and is inherently protected.

**SAVE THESE INSTRUCTIONS!**

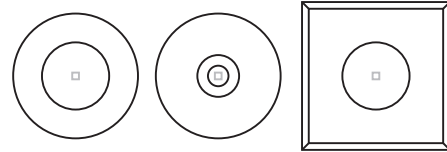

### Recessed Mount Installation

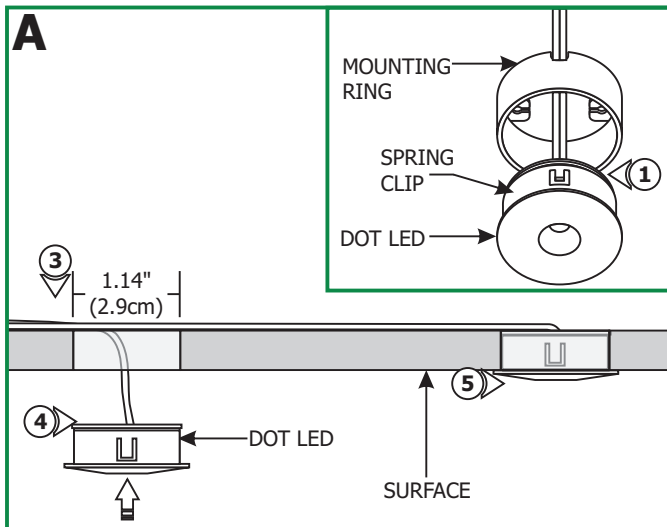

**NOTE:** Omit the steps below if surface mounting the Dot Lights.

- 1: Remove the mounting ring and discard it.
- 2: Mark the location where the Dot LED light is going to be recessed.
- 3: Drill out the marked location with a 1-1/8" circular saw.
- 4: Feed the Dot LED light wires through the cut out hole and snap the Dot LED light into the hole.
- 5: Repeat the steps 1 through 4 for the remaining Dots and then follow the "Power the Dot LED" steps.

- 1: Remove the mounting ring.
- 2: Use the mounting ring as a template to mark the screw location where the Dot LED light is going to be installed.
- 3: Use a 1/16" drill bit to drill pilot holes on marked locations.
- 4: Feed the Dot LED wires through the mounting ring. Hold the cord against the notch on the mounting ring while installing the mounting ring to the pilot holes with the provided two Phillips screws.
- 5: Pull the cord through the notch on the mounting clip and snap the Dot LED light into the mounting ring.
- 6: Repeat the steps 1 through 5 for the remaining Dots and then follow the "Power the Dot Lights" steps.

### Surface Mount Installation

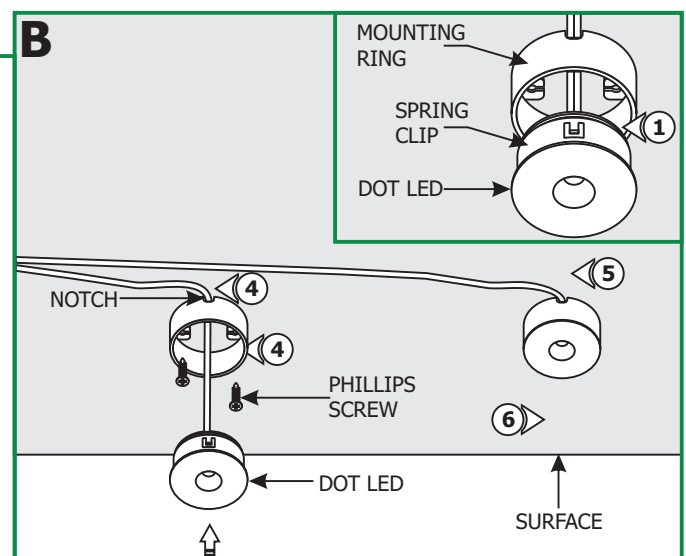

# Power the Dot Lights

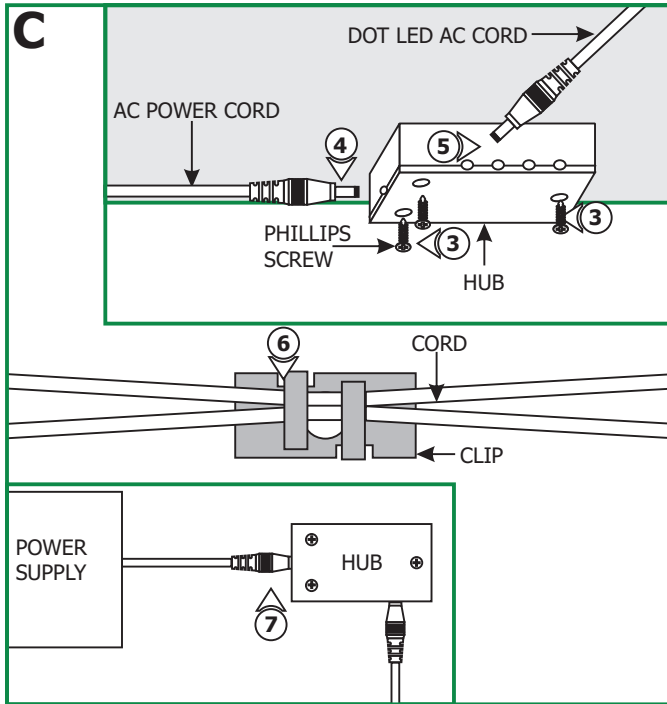

- 1: Mark the location where the hub is going to be installed.
- 2: Use a 1/16" drill bit to drill pilot holes on marked locations.
- 3: Mount the hub to the pilot holes with the three Phillips screws provided.
- 4: Connect the AC Power cord into the single port of the hub.
- 5: Connect each LED Dot AC cord into one port.
- 6: Use the provided clips to manage the Dots and Hub cords.
- 7: Connect the Hub AC power cord to the 12 volt power supply wires. Refer to the instructions provided with the power supply.

**NOTE:** Each Dot contains a 1 watt LED consuming a total of 1 watt.

## TYPICAL WIRING DIAGRAM

